

По чертежам, текстолитовое кольцо прижимает динамик через ППУ пенополиэтилен, продается на строительных рынках.

Текстолит покупаем у производителя, чем можно заменить не знаю, у нас нет проблем с текстолитом. Все вместе, это узел виброразвязки динамика от корпуса.

Подробнее в ветке про торнадо на Аудиопортале, там это все разжевано.

Окно под терминал не прорисовывал, откуда я знаю какой Вы будете применять.

Внутренняя поверхность, боковые, задняя и верхняя панели обклеена войлоком 10мм. На боковых и верхней панели 1 слой (10мм), на задней 2слоя (20мм). Первый слой приклеивается клеем ПВА, остальные пристреливаются скобами, **наклеивать слои друг на друга нельзя**. В полость образованную «ногой» вкладывается подушка, такая же заполняет остальной объем, подушки из «Ikea»

<http://www.ikea.com/ru/ru/catalog/products/20086615>

Войлок используем технический полугрубошерстный для прокладок марки «А».

<http://www.gorizont.org/voilok-info.html>

### KEY FEATURES

- High power handling (150 w AES)
- 2" (51.7 mm) copper voice-coil with polyimide fiber glass former
- Optimum winding length for increased linear excursion
- Designed for high power woofer applications



### GENERAL DESCRIPTION

The design concept of this low frequency transducer arises from the need of achieve a more resistant loudspeaker that matches the more and more power given by ultimate amplification systems. In order to accomplish that, almost every component of the speaker has been reconsidered. The SM-108 incorporates a 2" voice coil made with high quality materials: copper round wire with high temperature bonding strength and fiber glass former. Moreover, it features a powerful magnet system with rear air ventilation. By the other hand, its special surround guarantees the possibility of long displacements with linear behaviour. All these facts result in a 8" driver with extended and smooth low-mid frequency response, reduced harmonic distortion, good efficiency and excellent power handling (150 w AES). The SM-108 is specially recommended for woofer applications.

### FREQUENCY RESPONSE AND DISTORTION CURVES

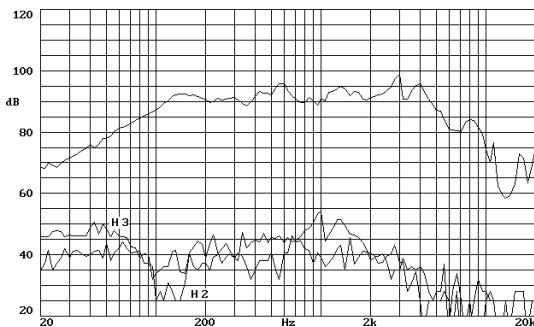

Note: on axis frequency response measured with loudspeaker standing on infinite baffle in anechoic chamber, 1w @ 1m.

### FREE AIR IMPEDANCE CURVE

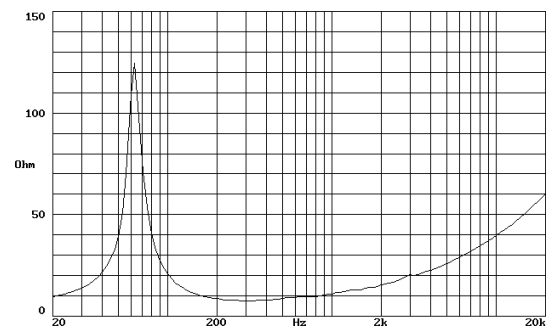

### PREDICTED LOW FREQUENCY RESPONSE

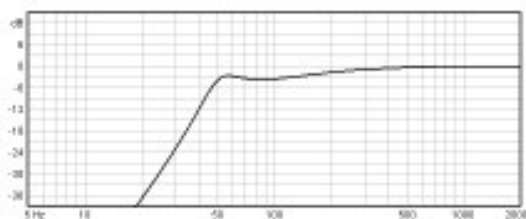

Note: Bass-reflex cabinet,  $V_b=20$  l,  $f_b=60$  Hz

### POWER COMPRESSION LOSSES

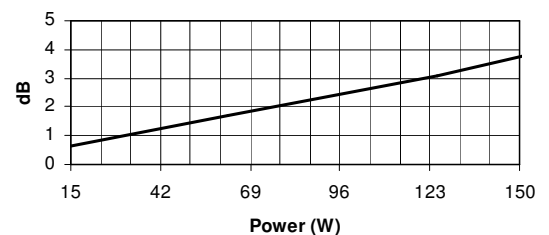

Note: These losses are calculated from a five minutes AES power test applying band limited pink noise (25-1200 Hz). The loudspeaker is free-air standing.

### TECHNICAL SPECIFICATIONS

Nominal diameter	200 mm. 8 in.
Rated impedance	8 ohms.
Minimum impedance	7.6 ohms.
Power capacity *	150 w AES
Program power	300 w
Sensitivity	95 dB 2.83v @ 1m @ 2 $\pi$
Frequency range	65 - 6000 Hz
Recom. enclosure vol.	10 / 30 l 0.35 / 1.06 ft. <sup>3</sup>
Voice coil diameter	51.7 mm. 2 in.
Magnetic assembly weight	2.8 kg. 6.17 lb.
BL factor	13 N / A
Moving mass	0.024 kg.
Voice coil length	15 mm.
Air gap height	7 mm.
X damage (peak to peak)	22 mm.

### MOUNTING INFORMATION

Overall diameter	212 mm. 8.35 in.
Bolt circle diameter	198 mm. 7.8 in.
Baffle cutout diameter:	
- Front mount	181 mm. 7.12 in.
- Rear mount	183 mm. 7.2 in.
Depth	94 mm. 3.7 in.
Volume displaced by driver	1.5 l 0.056 ft. <sup>3</sup>
Net weight	3.1 kg. 6.83 lb.
Shipping weight	3.25 kg. 7.15 lb.

### THIELE-SMALL PARAMETERS \*\*

Resonant frequency, fs	69 Hz
D.C. Voice coil resistance, Re	6.3 ohms.
Mechanical Quality Factor, Qms	7.01
Electrical Quality Factor, Qes	0.39
Total Quality Factor, Qts	0.37
Equivalent Air Volume to Cms, Vas	16 l
Mechanical Compliance, Cms	225 $\mu$ m / N
Mechanical Resistance, Rms	1.5 kg / s
Efficiency, $\eta_0$ (%)	1.3
Effective Surface Area, Sd (m <sup>2</sup> )	0.0220 m <sup>2</sup>
Maximum Displacement, Xmax	4 mm.
Displacement Volume, Vd	87 cm <sup>3</sup>
Voice Coil Inductance, Le @ 1 kHz	1.5 mH

### DIMENSION DRAWINGS

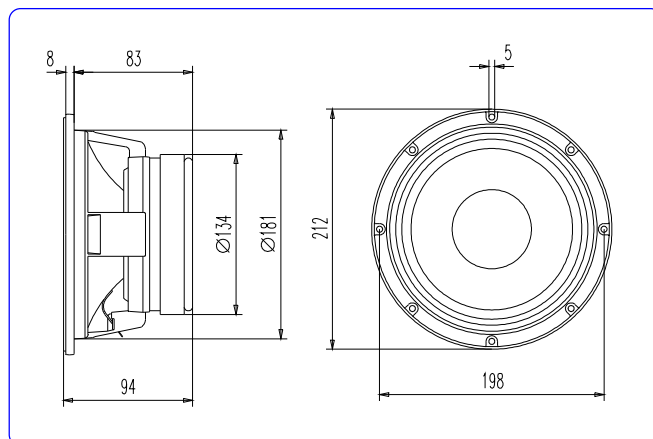

### MATERIALS

- **Voice coil:** copper round wire with high temperature bonding strength. Polyimide fiber glass former able to withstand high temperatures.
- **Cone:** high stiffness paper cone.
- **Surround:** special cloth surround designed for long displacements.
- **Spider:** cotton spider.
- **Metal parts:** effective protection against corrosion.
- **Basket:** specially designed die cast aluminium basket to avoid disturbing resonances.
- **Magnet:** high Curie temperature ferrite.

#### Notes:

\*The power capacity is determined according to AES2-1984 (r2003) standard. Program power is defined as the transducer's ability to handle normal music program material.

\*\*T-S parameters are measured after an exercise period using a preconditioning power test. The measurements are carried out with a velocity-current laser transducer and will reflect the long term parameters (once the loudspeaker has been working for a short period of time).



acústica beyma, s.a.

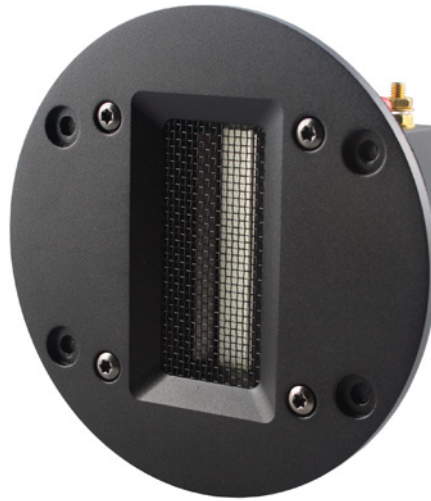

NeoCD3.0 True Ribbon Tweeter

#### FEATURES

- strong Neodymium magnet
- 3 inch enforced sandwich diaphragm
- build-in impedance convertor
- low distortion, very fast transition

Parameter	
Sensitivity	93dB/1m/2.83v
Power handling	17W nominal, 40W max
Frequency range	1,400-40,000Hz
Nominal impedance	7 ohm
DCR	0.02 ohm
Ribbon dimension	8mmX60mmX0.015mm
Effective ribbon area	480 square millimeter
Ribbon weight	18 milligram
Gap flux	0.6 Telsa average
Gap height	3 millimeter
Recommend crossover frequency	2,500Hz with 3-order
Net. Weight	650 gram

## SPL vs Freq

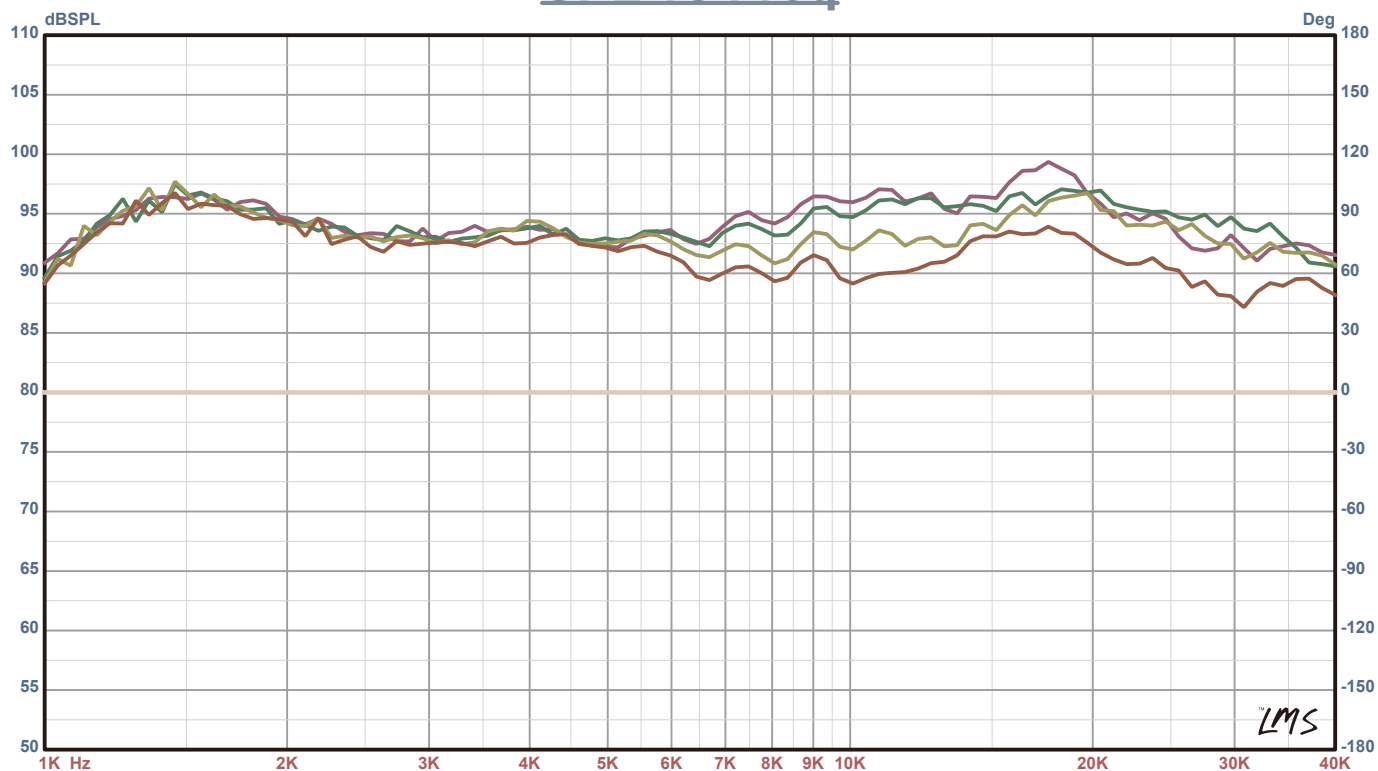

horizontal diffusion: on-axis, 15 degree, 30 degree, 45 degree

## SPL vs Freq

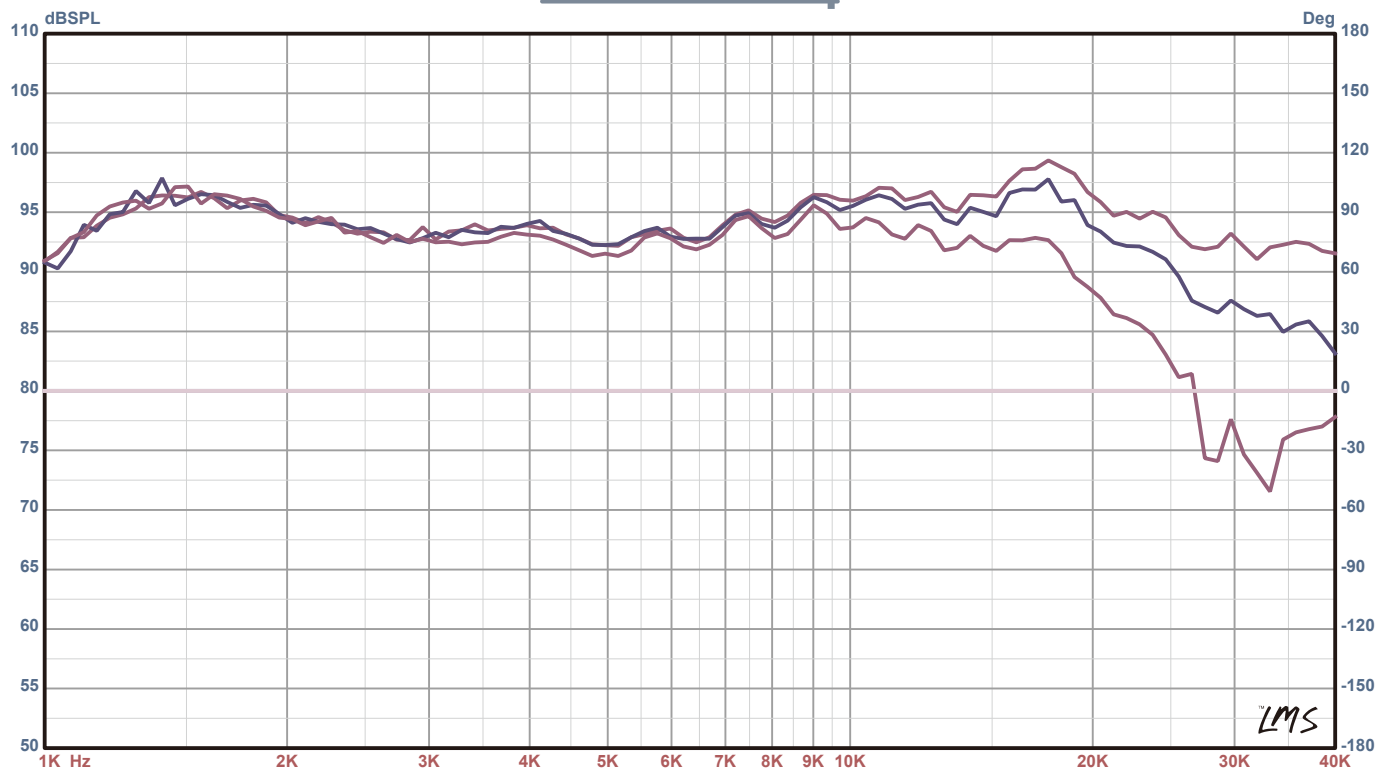

vertical diffusion: on-axis, 5 degree, 10 degree



